

Module SLE G1 SUNSET EXC

Modules SLE EXCITE

Product description

- For spotlights and downlights
- Sunset dimming – changes light colour with dimming level
- 100 % dimming level = 2.700 K, 5 % dimming level = 1.800 K
- Can be used with amplitude dimmable LED Drivers (no additional control)
- Housing with Snap-On feature for easy reflector mounting
- Luminous flux up to 1,700 lm at $t_p = 65\text{ }^\circ\text{C}$
- High colour consistency (MacAdam 3)
- Small LES (light emitting surface) diameter enables small beam angle for spotlights
- Fixing holes for M3 screws
- Cooling required
- 5-year guarantee



Standards, page 3

Colour temperatures and tolerances, page 8



LES15 with housing



LES11 with housing

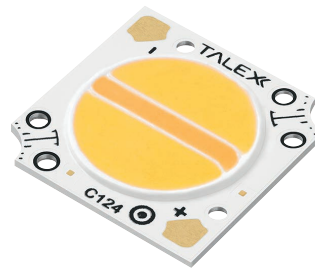

LES15



LES11





Module SLE G1 SUNSET EXC

Modules SLE EXCITE

Technical data

| | |
|--|----------------------|
| Beam characteristic | 115° |
| Ambient temperature range | -25 ... +50 °C |
| tp rated | 65 °C |
| tc ^① | Up to 100 °C |
| Max. allowed Silicon temperature | 150 °C |
| I _{rated} for LES11 | 350 mA |
| I _{rated} for LES15 | 500 mA |
| I _{max} for LES11 | 350 mA |
| I _{max} for LES15 | 500 mA |
| Max. DC forward current for LES11 ^② | 435 mA |
| Max. DC forward current for LES15 ^② | 850 mA |
| Max. permissible LF current ripple for LES11 | 435 mA |
| Max. permissible LF current ripple for LES15 | 850 mA |
| Max. permissible peak current for LES11 | 600 mA / max. 8 ms |
| Max. permissible peak current for LES15 | 1,200 mA / max. 8 ms |
| Max. working voltage for insulation nonSELV ^③ | 50 V |
| Max. working voltage for insulation SELV ^③ | 60 V |
| Insulation test voltage | 0.5 kV |
| ESD classification | Severity level 4 |
| Risk group (EN 62471:2008) | RG1 |
| Type of protection | IP00 |

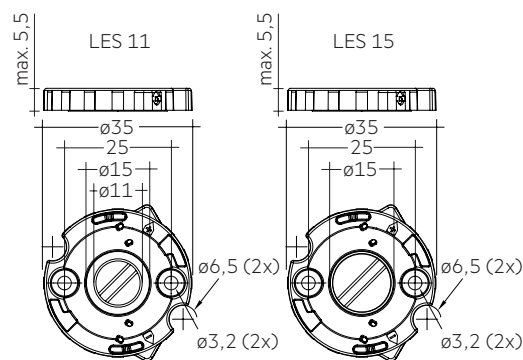

Dimensions in mm

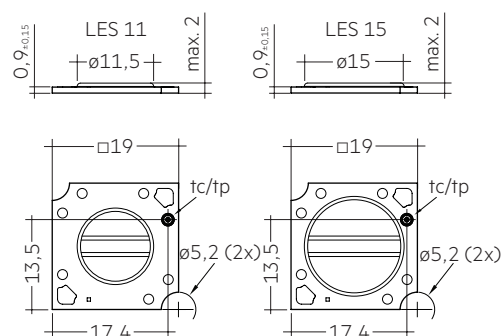

Dimensions in mm

Ordering data

| Type | Article number | Colour temperature | Housing | Packaging | Weight per pc. |
|-------------------------------------|----------------|--------------------|---------|-----------|----------------|
| SLE G1 11mm 1000lm 927 SUNSET R EXC | 89602602 | 1,800 – 2,700 K | no | 25 pc(s). | 0.001 kg |
| SLE G1 15mm 2000lm 927 SUNSET R EXC | 89602603 | 1,800 – 2,700 K | no | 25 pc(s). | 0.001 kg |
| SLE G1 11mm 1000lm 927 SUNSET H EXC | 89602605 | 1,800 – 2,700 K | yes | 50 pc(s). | 0.003 kg |
| SLE G1 15mm 2000lm 927 SUNSET H EXC | 89602606 | 1,800 – 2,700 K | yes | 50 pc(s). | 0.003 kg |

Specific technical data

| Type | Photo-metric code | Forward current | Luminous flux at tp = 25 °C ^④ | Luminous flux at tp = 65 °C ^④ | Power consumption ^⑤ | Min. forward voltage at tp = 65 °C | Max. forward voltage at tp = 25 °C | Luminous efficacy module at tp = 25 °C | Luminous efficacy module at tp = 65 °C | Luminous efficacy system at tp = 65 °C ^⑥ | Colour rendering index CRI |
|-----------------------------------|-------------------|-----------------|--|--|--------------------------------|------------------------------------|------------------------------------|--|--|---|----------------------------|
| SLE G1 11mm 1000lm 927 SUNSET EXC | 927/3x9 | 350 mA | 1,240 lm | 1,140 lm | 13.4 W | 34.4 V | 41.0 V | 91 lm/W | 85 lm/W | 77 lm/W | >90 |
| SLE G1 15mm 2000lm 927 SUNSET EXC | 927/3x9 | 500 mA | 1,850 lm | 1,700 lm | 18.1 W | 32.6 V | 38.9 V | 100 lm/W | 94 lm/W | 85 lm/W | >90 |

^① See derating curves in data sheet section 2.3.

^② I_{max} varies over the temperature of the LED module. See derating curves in data sheet section 2.3.

^③ The detailed explanation, see data sheet section 3.1.

^④ Tolerance range for optical and electrical data: ±10 %.

^⑤ Assumed efficiency for the LED Driver is 0.9.

^⑥ All values at tp = 65 °C.

1. Standards

EN 62031
 EN 62471
 IEC 62717
 IEC 61000-4-2
 UL 8750 - certificate number: E366084

1.1 Glow wire test

according to EN 62031 with increased temperature of 850 °C passed.

1.2 Photometric code

Key for photometric code, e. g. 930 / 369

| 1 st digit | | 2 nd + 3 rd digit | 4 th digit | 5 th digit | 6 th digit | |
|-----------------------|---------|---|-----------------------|---|--|---------------|
| Code | CRI | Colour temperature in Kelvin x 100 | McAdam initial | McAdam after 25% of the life-time (max.6000h) | Luminous flux after 25% of the life-time (max.6000h) | |
| 7 | 70 – 79 | | | | Code | Luminous flux |
| 8 | 80 – 89 | | | | 7 | ≥ 70 % |
| 9 | ≥90 | | | | 8 | ≥ 80 % |
| | | | | 9 | ≥ 90 % | |

1.3 Energy classification

| Type | Forward current | Energy classification |
|-----------------------------------|-----------------|-----------------------|
| SLE G1 11mm 1000lm 927 SUNSET EXC | 350 mA | A |
| SLE G1 15mm 2000lm 927 SUNSET EXC | 500 mA | A+ |

2. Thermal details

2.1 tp point, ambient temperature and life-time

The temperature at tp reference point is crucial for the light output and life-time of a LED product.

For SLE G1 SUNSET a tp temperature of 65°C has to be complied in order to achieve an optimum between heat sink requirements, light output and life-time.

Compliance with the maximum permissible reference temperature at the tp point must be checked under operating conditions in a thermally stable state. The maximum value must be determined under worst-case conditions for the relevant application.

To check the tc / tp temperature, the temperature sensor has to be mounted on the PCB at the marked position as stated in the drawing.

LES11

LES15

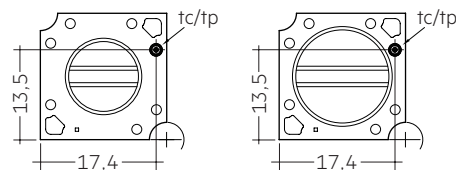

2.2 Storage and humidity

| | |
|---------------------|--------------|
| storage temperature | -30...+80 °C |
|---------------------|--------------|

Operation only in non condensing environment.
 Humidity during processing of the module should be between 30 to 70 %.

2.3 Derating curves

SLE G1 11mm 1000lm 927 SUNSET EXC

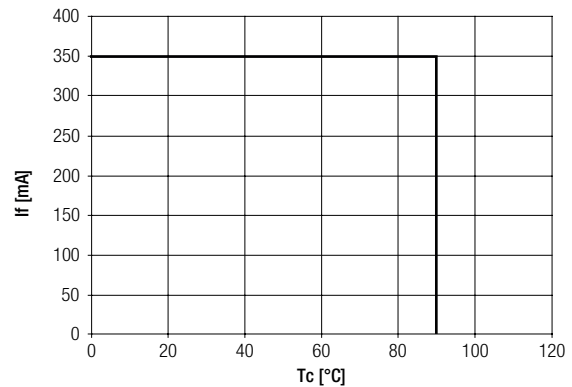

SLE G1 15mm 2000lm 927 SUNSET EXC

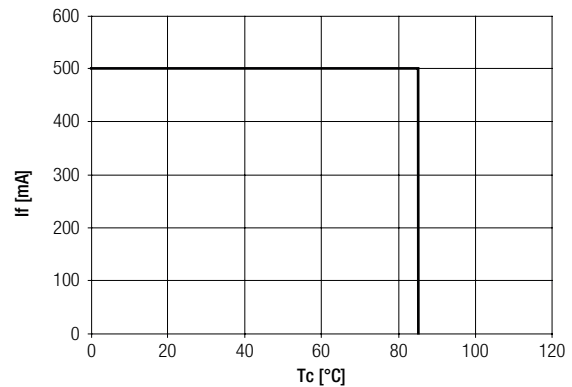

2.4 Thermal design and heat sink

The rated life of LED products depends to a large extent on the temperature. If the permissible temperature limits are exceeded, the life of the SLE G1 SUNSET will be greatly reduced or the SLE G1 SUNSET may be destroyed.

2.5 Heat sink values

SLE G1 11mm 1000lm 927 SUNSET EXC

| ta | tp | Operating current | R _{th, hs-a} |
|------|------|-------------------|-----------------------|
| 25°C | 65°C | 350 mA | 4.32 K/W |
| 30°C | 65°C | 350 mA | 3.74 K/W |
| 40°C | 65°C | 350 mA | 2.59 K/W |
| 50°C | 65°C | 350 mA | 1.43 K/W |

SLE G1 15mm 2000lm 927 SUNSET EXC

| ta | tp | Operating current | R _{th, hs-a} |
|------|------|-------------------|-----------------------|
| 25°C | 65°C | 500 mA | 3.21 K/W |
| 30°C | 65°C | 500 mA | 2.77 K/W |
| 40°C | 65°C | 500 mA | 1.89 K/W |
| 50°C | 65°C | 500 mA | 1.01 K/W |

Notes

The actual cooling can differ because of the material, the structural shape, outside influences and the installation situation. A thermal connection between SLE G1 SUNSET and heat sink with heat-conducting paste or heat conducting adhesive film is absolutely necessary.

Additionally the SLE G1 SUNSET has to be fixed on the heat sink with M3 screws to optimise the thermal connection.

Use of thermal interface material with thermal conductivity of $l > 1 \text{ W/mK}$ and layer thickness of interface material with max. $50 \mu\text{m}$ or a similar interface material where the quotient of layer thickness and thermal conductivity $b < 50 \mu\text{mmK/W}$.

3. Installation / wiring

3.1 Electrical supply/choice of LED Driver

SLE G1 SUNSET from Tridonic are not protected against over-voltages, over-currents, overloads or short-circuit currents. Safe and reliable operation can only be guaranteed in conjunction with a LED Driver which complies with the relevant standards. The use of LED Drivers from Tridonic in combination with SLE G1 SUNSET guarantees the necessary protection for safe and reliable operation.

If a LED Driver other than Tridonic is used, it must provide the following protection:

- Short-circuit protection
- Overload protection
- Overtemperature protection



Supply SLE G1 SUNSET by a constant current LED Driver with amplitude dimming. Operation with a constant voltage LED Driver will lead to an irreversible damage of the module. Wrong polarity can damage the SLE G1 SUNSET.



SLE G1 SUNSET are basic isolated up to 50 V against ground and can be mounted directly on earthed metal parts of the luminaire. If the max. output voltage of the LED Driver (also against earth) is above 50 V, an additional isolation between LED module and heat sink is required (for example by isolated thermal pads) or by a suitable luminaire construction.

At voltages $> 60 \text{ V}$ an additional protection against direct touch (test finger) to the light emitting side of the module has to be guaranteed.

This is typically achieved by means of a non removable light distributor over the module.

3.2 Wiring

Wiring with housing

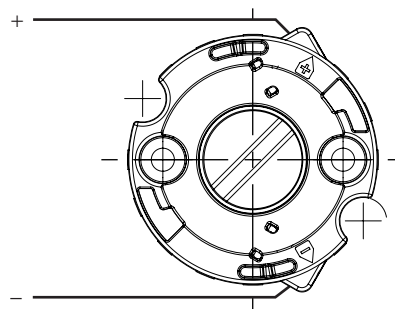

Wiring without housing

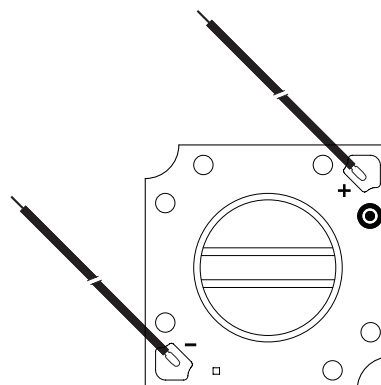

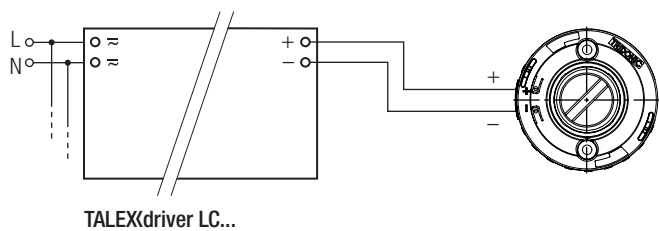
Wiring example**3.3 Wiring type and cross section**

The wiring has to be solid cable with a cross section of 0.5 to 0.75 mm² or with stranded wire with soldered ends with a cross section of 0.5 mm².

For the push-wire connection you have to strip the insulation (7 – 8 mm).

Removing wires by lightly pressing on the push button.

wire preparation:

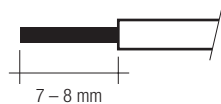
**3.4 Mounting instruction**

SLE G1 SUNSET from Tridonic which have to be installed on a heat sink have to be connected with heat-conducting paste or heat conducting adhesive film and fixed with M3 screws.

The fixing/cooling surface must be cleaned by removing all dirt, dust and grease before installing the LED modules.

None of the components of the SLE G1 SUNSET (substrate, LED, electronic components etc.) may be exposed to tensile or compressive stresses.



Max. torque for fixing: 0,5 Nm.

The LED modules are mounted with 2 screws per module. In order not to damage the modules only rounded head screws and an additional plastic flat washer should be used for LED modules without housing.



Chemical substance may harm the LED module. Chemical reactions could lead to colour shift, reduced luminous flux or a total failure of the module caused by corrosion of electrical connections.

Materials which are used in LED applications (e.g. sealings, adhesives) must not produce dissolver gas. They must not be condensation curing based, acetate curing based or contain sulfur, chlorine or phthalate.

Avoid corrosive atmosphere during usage and storage.

3.5 EOS/ESD safety guidelines

The device / module contains components that are sensitive to electrostatic discharge and may only be installed in the factory and on site if appropriate EOS/ESD protection measures have been taken. No special measures need be taken for devices/modules with enclosed casings (contact with the pc board not possible), just normal installation practice.

For further information for EOS/ESD safety guidelines and the ESD classification please refer to the brochure entitled <http://www.tridonic.com/esd-protection>.

3.6 Position of the SUNSET strip

Due to the production, the SUNSET strip can be arranged rotated by 90°.

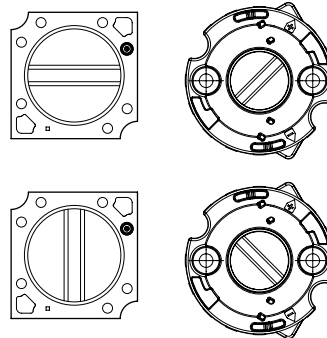

4. Life-time

4.1 Life-time, lumen maintenance and failure rate

The light output of an LED Module decreases over the life-time, this is characterized with the L value. L70 means that the LED module will give 70 % of its initial luminous flux. This value is always related to the number of operation hours and therefore defines the life-time of an LED module.

As the L value is a statistical value and the lumen maintenance may vary over the delivered LED modules. The B value defines the amount of modules which are below the specific L value, e.g. L70B10 means 10 % of the LED modules are below 70 % of the initial luminous flux, respectively 90 % will be above 70 % of the initial value.

In addition the percentage of failed modules (fatal failure) is characterized by the C value.

The F value is the combination of the B and C value. That means for F degradation and complete failures are considered, e.g. L70F10 means 10 % of the LED modules may fail or be below 70 % of the initial luminous flux.

4.2 Lumen maintenance

Life-time declarations are informative and represent no warranty claim. Preliminary calculated lifetime data until LM80 test reports are available.

SLE G1 11mm 1000lm 927 SUNSET EXC

| Operating current | tp temperature | L80 / F10 | L80 / F50 | L70 / F10 | L70 / F50 |
|-------------------|----------------|-----------|-----------|-----------|-----------|
| 350 mA | 65 °C | 49,000 h | >60,000 h | >60,000 h | >60,000 h |
| | 75 °C | 43,000 h | >60,000 h | >60,000 h | >60,000 h |
| | 85 °C | 38,000 h | 57,000 h | >60,000 h | >60,000 h |

SLE G1 15mm 2000lm 927 SUNSET EXC

| Operating current | tp temperature | L80 / F10 | L80 / F50 | L70 / F10 | L70 / F50 |
|-------------------|----------------|-----------|-----------|-----------|-----------|
| 500 mA | 65 °C | 37,000 h | 55,000 h | 59,000 h | >60,000 h |
| | 75 °C | 32,000 h | 48,000 h | 51,000 h | >60,000 h |
| | 85 °C | 28,000 h | 42,000 h | 45,000 h | >60,000 h |

SLE G1 19mm 3500lm 927 SUNSET EXC

5. Electrical values

5.1 Declaration of electrical parameters

Irated ... Nominal operating current the module is designed for.

I_{max} ... Max. permissible continuous operating current.

Max. DC forward current ... Max. permissible continuous operating current incl. The tolerances of the LED driver. LED module may be destroyed if this value is exceeded.

Max. permissible LF current ripple ... Max. output current of the LED driver incl. Tolerances and LF current ripple must not exceed this value.

Max. permissible peak current ... The max. output peak current of the LED driver must not exceed this value.

5.2 Forward voltage vs. forward current

SLE G1 11mm 1000lm 927 SUNSET EXC

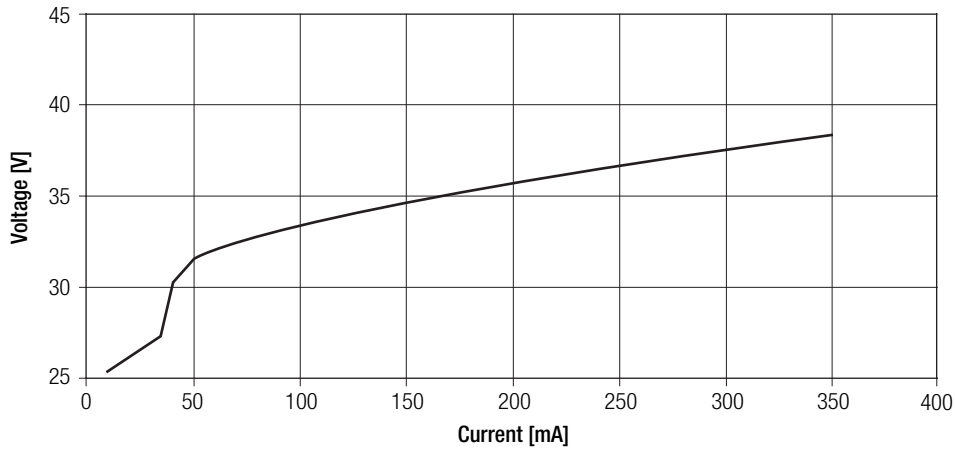

SLE G1 15mm 2000lm 927 SUNSET EXC

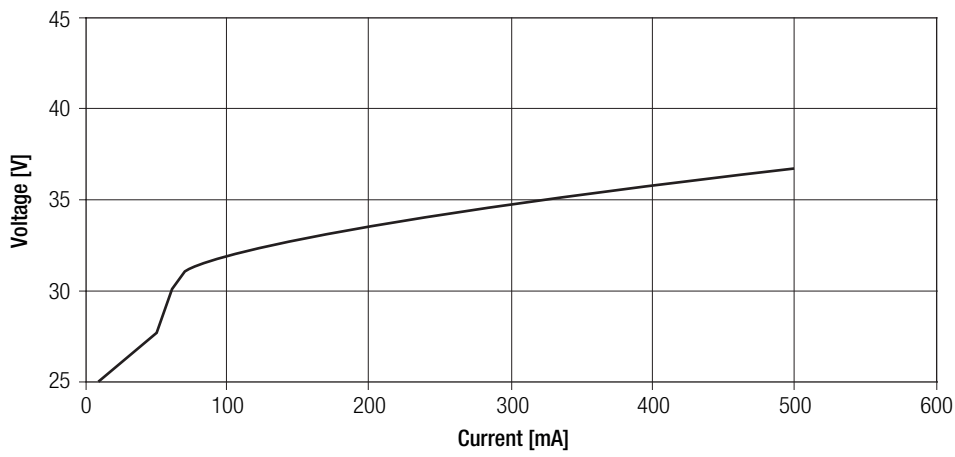

5.3 Forward voltage vs. tp temperature

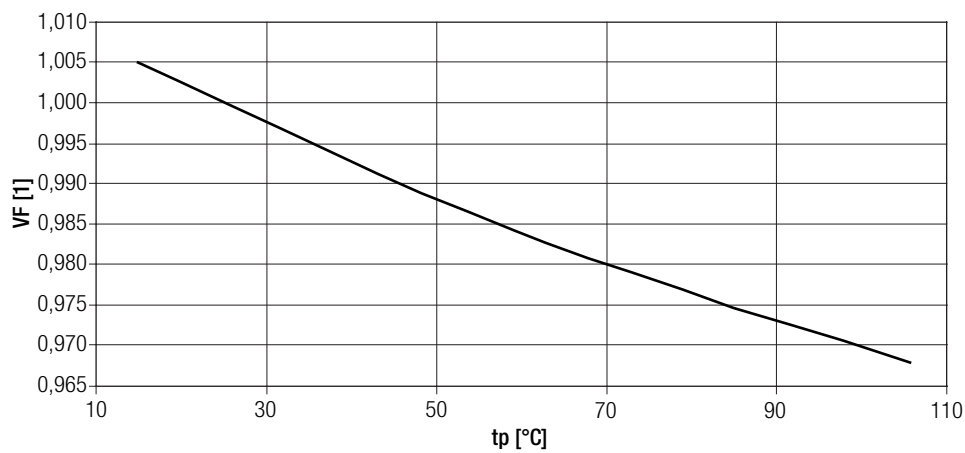

The diagrams based on statistic values.
The real values can be different.

6. Photometric characteristics

6.1 Coordinates and tolerances according to CIE 1931

The specified colour coordinates are measured integral after a settling time of 100 ms. The current impuls depends on the module type.

| Module type | Current impulse | Colour temperature |
|-------------------------------|-----------------|--------------------|
| SLE G1 11mm 1000lm 927 SUNSET | 350 mA | 2,700 K |
| | 17,5 mA | 1,800 K |
| SLE G1 15mm 2000lm 927 SUNSET | 500 mA | 2,700 K |
| | 25,0 mA | 1,800 K |

The ambient temperature of the measurement is $t_a = 25\text{ }^\circ\text{C}$.
The measurement tolerance of the colour coordinates are $\pm 0,01$.

2,700 K (100 % dimming level)

| | x0 | y0 |
|--------|--------|--------|
| Centre | 0,4599 | 0,4106 |

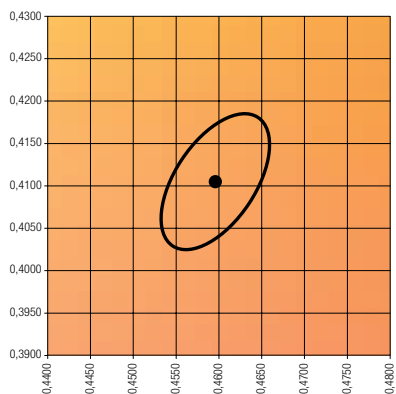

MacAdam ellipse: 3SDCM

1,800 K (5 % dimming level)

| | x0 | y0 |
|--------|--------|--------|
| Centre | 0,5492 | 0,4082 |

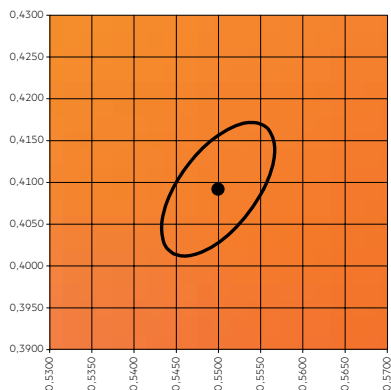

MacAdam ellipse: 3SDCM

6.2 Relative luminous flux vs. tp temperature

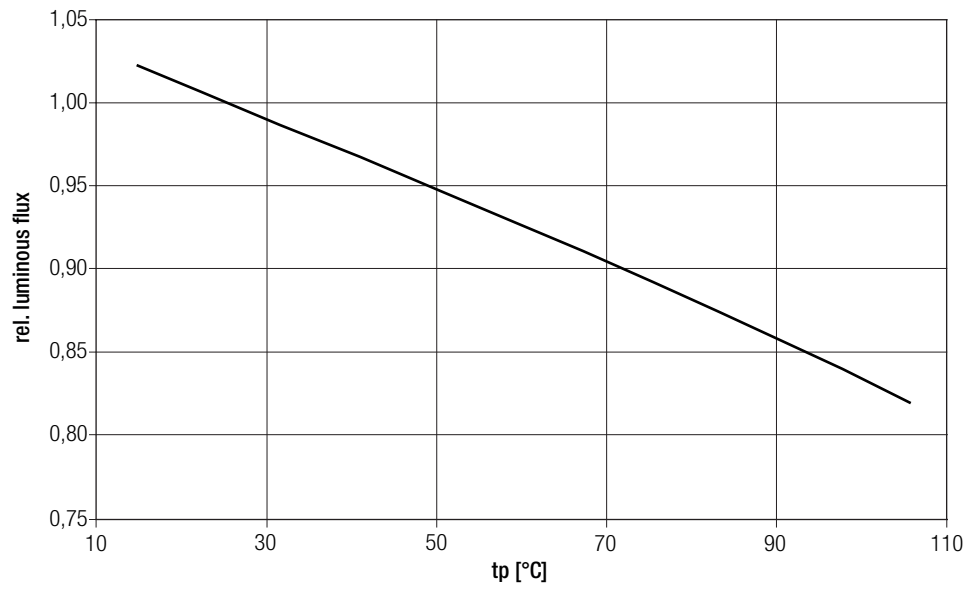

6.3 Colour temperature vs. dimming range

SLE G1 11mm 1000lm 927 SUNSET EXC

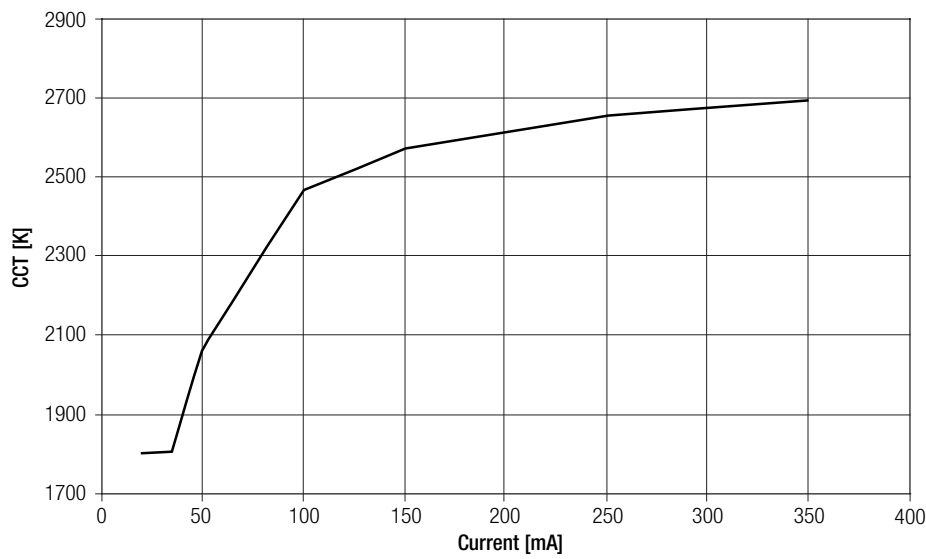

SLE G1 15mm 2000lm 927 SUNSET EXC

